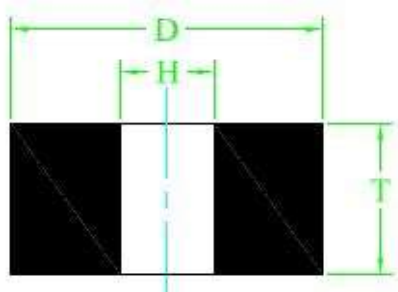

Polycrystalline Diamond (PCD) & Cubic Boron Nitride (CBN) Wheels

Plain Wheels

Unit: mm

Shape: TYPE 1A8 Bonds: Resin (R), Metal(M), Vitriified(V) Item No.: NDR/CBR1A8-D*T*H-GRIT	D(MM)	D(IN)	T	H
	5	0.200	4, 6, 8	2
	6	0.250	4, 6, 8	2
	8	0.315	6, 8, 10	3
	10	0.400	6, 8, 10	3
	12	0.472	8, 10, 12	4
	14	0.551	8, 10, 12, 16	4
	16	0.630	8, 10, 12, 16, 18	4
	18	0.710	10, 12, 16, 18	6
	20	0.787	10, 12, 16, 18, 20	6
				
* Imperial sizes are available too * Custom sizes are available upon request				

Plain Wheels

Unit: mm

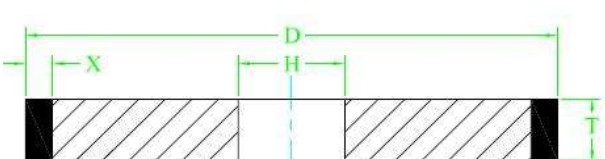
Shape: TYPE 1A1/T2 Bonds: Resin (R), Metal(M), Vitriified(V) Item No.: NDR/CBR1A1-D*T*X-GRIT	D(mm)	D(in)	T	X	H
	16	0.630	4 - 16	2	4
	18	0.710	4 - 20	2	6
	20	0.787	4 - 20	3	6
	25	1.000	4 - 20	3	6
	30	1.281	4 - 20	3	10
	40	1.575	4 - 20	3	10
	50	2.00	4 - 20	3	10
	63	2.50	4 - 20	3	10
	75	3.00	4 - 20	3	10, 20
	80	3.15	4 - 20	3	10, 20
	100	4.00	4 - 20	4	20
	125	5.00	4 - 20	4	20, 32
	150	6.00	4 - 32	4	32
	175	7.00	4 - 32	4	32
	200	8.00	4 - 32	4	32, 75
	250	10.00	6 - 40	5	75, 127
	300	12.00	8 - 40	5 - 10	127, 203
	350	14.00	8 - 40	5 - 10	127, 203
	400	16.00	8 - 40	5 - 10	203
450	18.00	12 - 50	6 - 10	203	
500	20.00	12 - 50	6 - 10	203, 305	
600	24.00	12 - 50	10	203, 305	
750	30.00	12 - 50	10	203, 305	
					
* Imperial sizes are available too * Custom sizes are available upon request					

Polycrystalline Diamond (PCD) & Cubic Boron Nitride (CBN) Wheels

Plain Angle Wheels Abrasive in Periphery

Unit: mm

Shape: TYPE 1V1	D(mm)	D(in)	T	X	V
Bonds: Resin (R), Metal(M), Vitriified(V)	75	3	5,6,8,10,15	3,4,5,6,8	35° - 85°
Item No.: NDR/CBR 1V1-D*T*H*X*V-GRIT	100	4			
	125	5			
	150	6			
	200	8			
	250	10			
* Imperial sizes are available too					
* Custom sizes are available upon request					

Plain Angle Wheels

Unit: mm

Shape: TYPE 4B1	D(mm)	D(in)	T	X	W
Bonds: Resin (R), Metal(M), Vitriified(V)	50	2	6, 8, 10	0.5	5 - 8
Item No.: NDR/CBR 4R1-D*T*H*X*W-GRIT	63	3			
	75	3			
	100	4			
	125	5			
	150	6			
	175	7			
	200	8			
* Imperial sizes are available too					
* Custom sizes are available upon request					

Plain Cup Wheels

Unit: mm

Shape: TYPE 6A2	D(mm)	D(in)	T	E	X	W
Bonds: Resin (R), Metal(M), Vitriified(V)	75	3	18	10	1 - 5	3, 5, 6, 10
Item No.: NDR/CBR 6A2-D*T*H*X*W-GRIT	100	4				
	125	5				
	150	6	22	5, 6, 10, 12		
	175	7	25	13		5, 6, 10, 12, 20
	200	8			6, 10, 12, 20, 25	
* Imperial sizes are available too						
* Custom sizes are available upon request						

Plain Cup Wheels with Countersink Bolt Holes

Unit: mm

Shape: TYPE 6A2C	D(mm)	D(in)	T	E	X	W
Bonds: Resin (R), Metal(M), Vitriified(V)	75	3	18	10	1-5	3, 5, 6, 10
Item No.: NDR/CBR 6A2C-D*T*H*X*W-GRIT	100	4				
	125	5				
	150	6	22	5, 6, 10, 12		
	175	7	25	13		5, 6, 10, 12, 20
	200	8			6, 10, 12, 20, 25	
* Imperial sizes are available too						
* Custom sizes are available upon request						

Polycrystalline Diamond (PCD) & Cubic Boron Nitride (CBN) Wheels

Plain Cup Wheels Abrasive in Periphery

Unit: mm

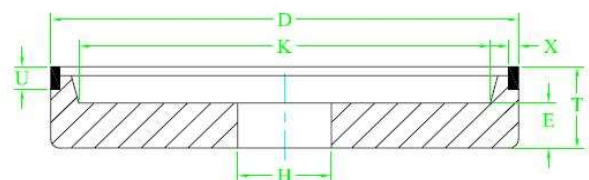
Shape: TYPE 6A9	D(mm)	D(in)	T	E	X	U	K
Bonds: Resin (R), Metal(M), Vitriified(V)	75	3	25	10	2, 3, 4, 6	6 - 10	60
Item No.: NDR/CBR 6A9-D*T*H*X*U-GRIT	100	4	30				80
	125	5	30				107
	150	6	35	10, 15			132
	175	7					150
	200	8					175
	250	10	50	12, 15	225		
* Imperial sizes are available too							
* Custom sizes are available upon request							

Double Sides Cup Wheels

Unit: mm

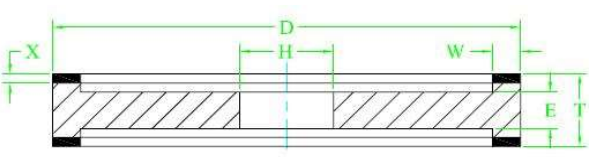
Shape: TYPE 9A3	D(mm)	D(in)	T	E	X	W
Bonds: Resin (R), Metal(M), Vitriified(V)	100	4	22	10, 14, 18	2, 3, 4	6 - 15
Item No.: NDR/CBR 9A3-D*T*H*X*W-GRIT	125	5				
	150	6	25, 35	14, 18		
	175	7				
	200	8	30, 35			
* Imperial sizes are available too						
* Custom sizes are available upon request						

Flaring Cup Wheels

Unit: mm

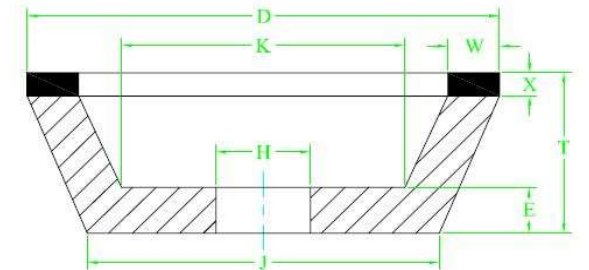
Shape: TYPE 11A2	D(mm)	D(in)	T	E	X	W	J
Bonds: Resin (R), Metal(M), Vitriified(V)	75	3	30	10	3 - 6	3 - 10	55
Item No.: NDR/CBR 11A2-D*T*H*X*W-GRIT	100	4	35				75
	125	5	40				100
	150	6	50				115
* Imperial sizes are available too							
* Custom sizes are available upon request							

Flaring Cup Wheels

Unit: mm

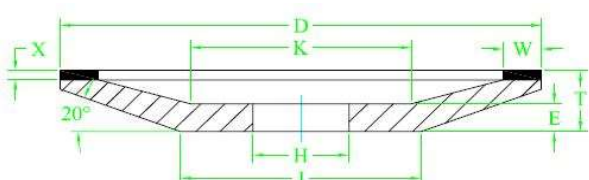
Shape: TYPE 12A2/20°	D(mm)	D(in)	T	E	X	W	J
Bonds: Resin (R), Metal(M), Vitriified(V)	75	3	6	5	1 - 5	3 - 10	37
Item No.: NDR/CBR 12A2/20°-D*T*H*X*W-GRIT	100	4	8	6			50
	125	5	10	9			65
	150	6	10	9			84
	200	8	12	11			96
	250	10	14	13			130
* Imperial sizes are available too							
* Custom sizes are available upon request							

Polycrystalline Diamond (PCD) & Cubic Boron Nitride (CBN) Wheels

Flaring Cup Wheels Abrasive in Periphery

Unit: mm

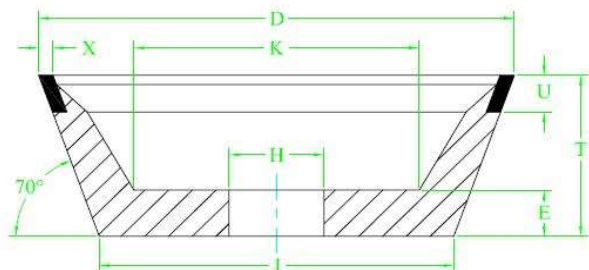
Shape: TYPE 11V9	D(mm)	D(in)	T	E	X	U	J
Bonds: Resin (R), Metal(M), Vitrified(V)	75	3	30	10	2, 3, 4	6,10,12	53
Item No.: NDR/CBR 11V9-D*T*H*X*U-GRIT	100	4	35				75
	125	5	40				96
	150	6	50				115
<p>* Imperial sizes are available too</p> <p>* Custom sizes are available upon request</p>							

Flaring Cup Wheels

Unit: mm

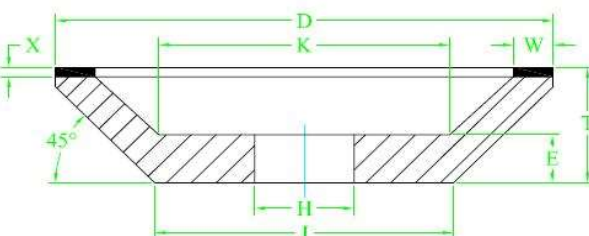
Shape: TYPE 12A2/45°	D(mm)	D(in)	T	E	X	W	J
Bonds: Resin (R), Metal(M), Vitrified(V)	75	3	32	9	1 - 5	3 - 10	37
Item No.: NDR/CBR 12A2/45°-D*T*H*X*W-GRIT	100	4		56			
	125	5		80			
	150	6		106			
	200	8		156			
	250	10		206			
<p>* Imperial sizes are available too</p> <p>* Custom sizes are available upon request</p>							

Flaring Cup Wheels Abrasive in Periphery & End

Unit: mm

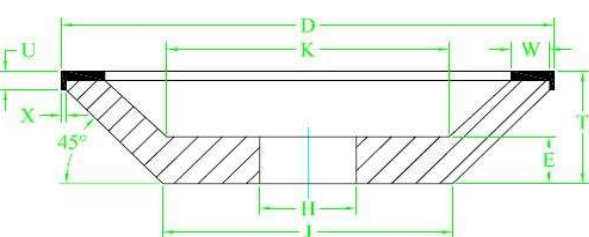
Shape: TYPE 12C9/45°	D(mm)	D(in)	T	E	X	U	W
Bonds: Resin (R), Metal(M), Vitrified(V)	75	3	22	10	1 - 5	4, 5	5, 10
Item No.: NDR/CBR 12C9/45°-D*T*H*X*U-GRIT	100	4					
	125	5					
	150	6					
<p>* Imperial sizes are available too</p> <p>* Custom sizes are available upon request</p>							

Polycrystalline Diamond (PCD) & Cubic Boron Nitride (CBN) Wheels

Flaring Cup Wheels

Unit: mm

Shape: TYPE 12V9/45°	D(mm)	D(in)	T	E	X	U	J
Bonds: Resin (R), Metal(M), Vitrified(V)	75	3	20	10	2, 3, 4	6, 10	35
Item No.: NDR/CBR 12V9/45°-D*T*H*X*U-GRIT	100	4					60
	125	5					75
	150	6					100
<p>* Imperial sizes are available too * Custom sizes are available upon request</p>							

Plain Wheels with Reinforced Body

Unit: mm

Shape: TYPE 14A1	D(mm)	D(in)	T	X	U
Bonds: Resin (R), Metal(M), Vitrified(V)	50	1	4 - 20	3	4 - 20
Item No.: NDR/CBR 14A1-D*T*H*X*U-GRIT	63	2.5	4 - 20	3	4 - 20
	75	3	4 - 20	3	4 - 20
	100	4	4 - 20	4	4 - 20
	125	5	4 - 20	4	4 - 20
	150	6	4 - 32	4	4 - 32
	175	7	4 - 32	4	4 - 32
	200	8	4 - 32	4	4 - 32
	250	10	6 - 40	5	6 - 40
	300	12	8 - 40	5	8 - 40
	350	14	8 - 40	5	8 - 40
	400	16	8 - 40	6	8 - 40
	450	18	12 - 60	6	12 - 60
	500	20		6	
	600	24		6	
750	30	6			
<p>* Imperial sizes are available too * Custom sizes are available upon request</p>					

Plain Wheels with Reinforced Body & V-Edges

Unit: mm

Shape: TYPE 14E1	D(mm)	D(in)	T	U	X	J	V
Bonds: Resin (R), Metal(M), Vitrified(V)	75	3	6	3, 4, 5	3 - 10	50	30° 35° 45° 60° 90°
Item No.: NDR/CBR 14E1-D*T*H*X*U-GRIT	100	4				70	
	125	5				100	
	150	6				120	
	175	7	140				
	200	8	160				
	250	10	200				
	<p>* Imperial sizes are available too * Custom sizes are available upon request</p>						

Polycrystalline Diamond (PCD) & Cubic Boron Nitride (CBN) Wheels

Plain Wheels with Reinforced Body & R-Edges

Unit: mm

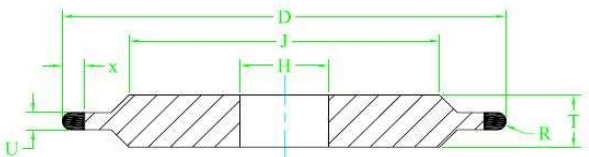
Shape: TYPE 14F1	D(mm)	D(in)	T	U	X	J	V	
Bonds: Resin (R), Metal(M), Vitrified(V)	75	3	6	1.5 - 5	3 - 10	60	Custom	
Item No.: NDR/CBR 14F1-D*T*H*X*U-GRIT	100	4				8		80
	125	5						10
	150	6	120					
	175	7	140					
		200	8			175		
		250	10	210				
	* Imperial sizes are available too * Custom sizes are available upon request							

Wheels for Main Edge Relief Angle of Saw Blades

Unit: mm

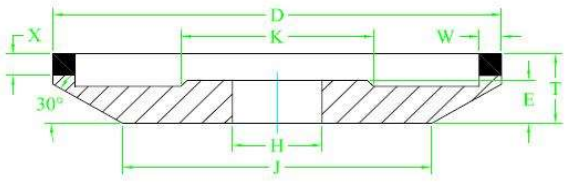
Shape: TYPE SWM001	D(mm)	D(in)	T	E	X	W	H
Bonds: Resin (R), Metal(M), Vitrified(V)	100	4	16	10	5	3 - 5	20
Item No.: NDR/CBR SWM001-D*T*H*X*W-GRIT	125	5		12	5, 6		32
	150	6		12	5, 6		32
	* Imperial sizes are available too * Custom sizes are available upon request						

Wheels for Side Clearance of Saw Blades

Unit: mm

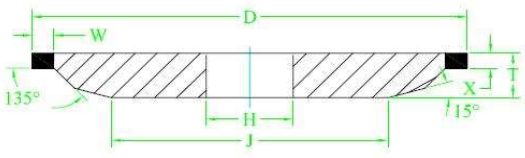
Shape: TYPE SWM002	D(mm)	D(in)	T	X	W	H
Bonds: Resin (R), Metal(M), Vitrified(V)	76	3	10 - 14	3, 4, 5	4 - 6	20
Item No.: NDR/CBR SWM002-D*T*H*X*W-GRIT	100	4				32
	125	5				32
	* Imperial sizes are available too * Custom sizes are available upon request					

Wheels for Rake Faces of Saw Blades

Unit: mm

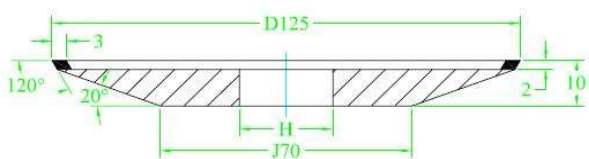
Shape: TYPE SWM003	D(mm)	D(in)	T	X	W	H
Bonds: Resin (R), Metal(M), Vitrified(V)	100	4	10	1, 2	2 - 10	16 - 32
Item No.: NDR/CBR SWM003-D*T*H*X*W-GRIT	125	5				
	150	6				
	